

# ENHANCING PRODUCTIVITY AT WORK

**INNOFITT™**  
Intelligent Workplace Solutions





## INTELLIGENT WORKPLACE ACCESSORIES

Innofitt Systems manufactures intelligent workplace accessories, helping offices transform into some of the most productive work places. Innofitt helps to make people more efficient and productive. Backed by over a decade of experience in the industry, our exclusive product range is recommended by leading architects. Our clients list includes top furniture manufacturers, furniture importers and interior contractors and select corporate/ institutions who have installed our products at hundreds of prestigious sites.

### MANUFACTURING PLANT

Innofitt Systems Pvt Ltd is the only company in India dedicated only to manufacturing accessories for the workplace. Pioneered by a team of professionals and technically qualified people, its products are manufactured at its production unit at Pune.

### INNOFITT THE OFFICE SPECIALIST

We have made a conscious choice to make the office domain our forte. By focusing on and understanding this segment fully, we strive to align our products and solutions to our customer's goal. Consequently our products are specifically designed for offices and are easy to install, use and maintain. Innofitt helps architects, interior contractors and furniture manufacturers to meet their goals of making highly functional, productive and comfortable office spaces.

### ERGONOMICS OUR MANTRA FOR WELLNESS

We apply the science of Ergonomics to our products so that they provide natural comfort and avoid stress or injury. Our designs ensure that humans and technology work in complete harmony leading to employee wellness. We truly understand the need of the hour, and products like our height adjustable Monitor Arms, Footrests and Articulated Keyboard Drawers are testament to this fact. Innofitt solutions are tailored to preserve health, improve productivity and maintain comfort in the work place.





# STACK IT! ROLL IT! FOLD IT!

## FOLDING TABLE



Product code  
• IS FT 02

SMARTER &  
STRONGER

- German Mechanism
- Stackable
- All Four Lockable Castors
- Colour: MSG

Available Sizes :

- 600 x 1200 mm
- 600 x 1500 mm
- 750 x 1200 mm
- 750 x 1500 mm



Product code  
• IS FT 03

- Premium Design
- Stackable
- All Four Lockable Castors
- Colour: White

Available Sizes :

- 1200 mm ~ 1800 mm
- 600 mm ~ 800 mm



# HEIGHT ADJUSTABLE TABLE

## TAKE A STAND FOR YOUR HEALTH!

### OVERVIEW:

Employees spend up to 8-9 hours of each workday sitting. With this level of inactivity on the workstation, a whole host of serious problems cannot be far behind. Muscular issues, back pain, poor blood circulation, diabetes and many more ergonomics issues.

### SOLUTION:

Using a Height Adjustable Table and alternating between sitting and standing will help in keeping the muscles flexible while working. Height Adjustable Tables also help in burning calories, and keeps you healthy and fit, resulting in more productivity at work.



### ADVANTAGES OF HEIGHT ADJUSTABLE TABLE:

- Alternate between sitting & standing positions
- Control panel with 4 memory presets
- LED Display showing height indicator
- Height adjustment is customizable to individual needs
- Anti-collision feature (in 2 Motor 2 Stage and 2 Motor 3 Stage Models)



# THE HEIGHT OF CONVENIENCE AT YOUR FINGERTIPS!

- ◆ EASY TO OPERATE, SMOOTH TO LIFT
- ◆ HIGH QUALITY RUGGED STEEL
- ◆ SOFT START/STOP TECHNOLOGY, NO JERKING AND NO JOLTING
- ◆ COLOUR: WHITE



Product Code  
•IS ET 2M 2S

**2 MOTOR,  
2 STAGE**

- ◆ With Anti-Collision Feature
- ◆ Minimum Height: 710 mm
- ◆ Maximum Height: 1170 mm
- ◆ All heights including table top
- ◆ Control Panel with LED Display & 4 Memory Presets



Product Code  
•IS ET 2M 3S

**2 MOTOR,  
3 STAGE**

- ◆ Minimum Height: 660 mm
- ◆ Maximum Height: 1310 mm
- ◆ All heights including table top
- ◆ Control Panel with LED Display & 4 Memory Presets

# HEIGHT ADJUSTABLE TABLE



Product code  
•IS MT 2S

## MANUAL, 2 STAGE

- ◆ Minimum Height: 700 mm
- ◆ Maximum Height: 1150 mm
- ◆ All heights including table top

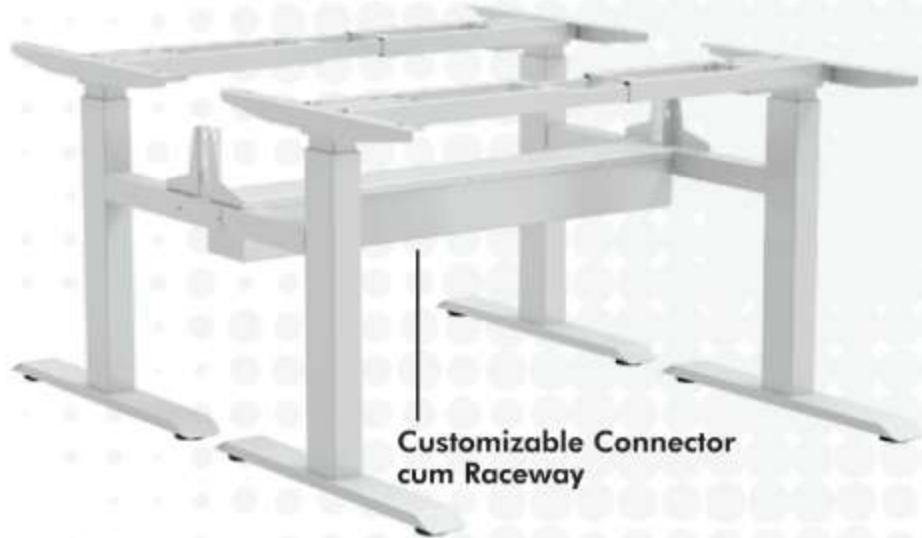

Product code  
•IS ET 3S 4M B2B

## BACK TO BACK, 2 STAGE

- ◆ Minimum Height: 710 mm
- ◆ Maximum Height: 1170 mm
- ◆ All heights including table top
- ◆ Control Panel with LED Display & 4 Memory Presets



Product code  
•IS ET 3S 3M L

## L SHAPED, 3 STAGE

- ◆ Minimum Height: 660 mm
- ◆ Maximum Height: 1310 mm
- ◆ All heights including table top
- ◆ Control Panel with LED Display & 4 Memory Presets

# PDX RANGE

- ◆ MADE IN INDIA
- ◆ ALL CONFIGURATIONS POSSIBLE
- ◆ IMPORT SUBSTITUTE
- ◆ FASTER LEAD PERIODS



**CONSOLE**



**SURFACE**



**PDU - RACEWAY**



**PDU Under Table**



### PDX CONSOLE

An elegant solution for connectivity on all types of tables



### PDX SURFACE

Fixed on the surface of the table



### PDX PDU

Fixed under the table on Raceway



### PDX PDU UT

Fixed under the table



— CE CERTIFIED —

## AVAILABLE IN VARIOUS CONFIGURATION OPTIONS

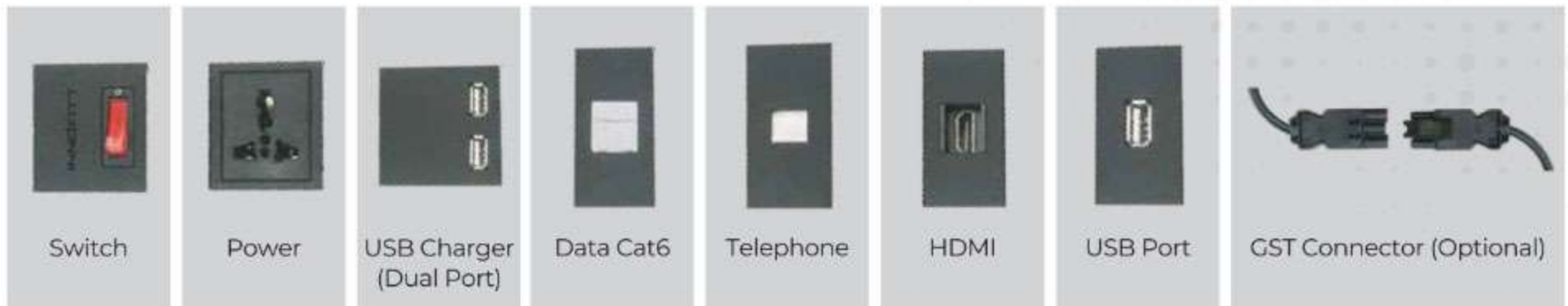

- ◆ PERFECT FOR INDIVIDUAL WORKSTATIONS AND MEETING ROOMS
- ◆ SPACE SAVING



Switch Socket  
CE Marked



Product code  
•IS CMP PSUD

POWER, SWITCH,  
USB CHARGER, DATA



Product code  
•IS CMP PSUH

POWER, SWITCH,  
USB CHARGER, HDMI



Product code  
•IS CMP PSD

POWER, SWITCH, DATA



Product code  
•IS CMP PSUU

POWER, SWITCH, 2 USB CHARGER



Product code  
•IS CMP PSU

POWER, SWITCH,  
USB CHARGER



Product code  
•IS CMP PSH

POWER, SWITCH, HDMI



Product code  
•IS CMP PS

POWER, SWITCH

Switch Socket  
CE Marked

Out to Out Size: Ø 100  
Cut Out Size: Ø 92



Colour: Silver

### DeskPort 180 Motorized

#### FTB - 180

- ◆ Cutout: 104mm x 373mm
- ◆ Out to out: 110mm x 407mm
- ◆ Configuration: 3 Power, 2 Data & 1 HDMI



Colour: Silver

### DeskPort 170 Revolve

#### FTB - 170

- Add a touch of class to your office
- Pre-wired
- Cutout: 103mm x 267/322mm
- Out to out: 110mm x 300/352mm
- Configuration:
  - 8A : 2 Power, Switch, 2 Data, USB
  - 10A: Switch, 3 Power, 2 Data & 1 HDMI

# AN ELEGANT ADDITION TO EVERY OFFICE!



The perfect solution for connectivity on:

- ◆ Conference Tables
- ◆ Meeting Room Tables
- ◆ Desking Tables
- ◆ Linear Workstations
- ◆ Lab Furniture
- ◆ Hotel Rooms
- ◆ Educational Furniture
- ◆ TV Studios
- ◆ Eliminates Carpentry Work
- ◆ Smart Looks
- ◆ Easy to install



**FTB - 154**  
Colour: Metallic Silver Grey



**FTB - 154 - With Accessories**

## DeskPort 154 Manual

- ◆ Available in 6, 8, 10 & 12 modules
- ◆ Elegant Design
- ◆ Option of Gasket or Brush
- ◆ Cutout: 132 mm x 216/266/316/366mm
- ◆ Out to out: 154 mm x 232/282/332/382mm

## DeskPort Hydraulic

- ◆ Hydraulic Mechanism
- ◆ Smooth Operation
- ◆ Cutout: 110mm x 225mm
- ◆ Out to out: 118mm x 265mm

**FTB - 160**  
Various Configurations Available

**FTB - 164**  
Configuration:  
2 Power, 2 Data, VGA, HDMI, Audio, USB

**FTB - 160**



Colour: Silver

**FTB - 164**



Colour: Silver

## DeskPort XioFlip

- ◆ Easy to access electricals under the table from all three sides
- ◆ Import Substitute
- ◆ With optional soft close feature
- ◆ Option: with or without Brush
- ◆ Available in: 300mm & 450mm
- ◆ Cutout: 140mm x 319/468mm
- ◆ Out to out: 154mm x 332/482mm



## DeskPort Access Flap

- ◆ Easy to access electricals under the table
- ◆ With optional soft close feature
- ◆ Available in 300mm, 450mm & 600mm
- ◆ Cutout: 132mm x 316/466/616mm
- ◆ Out to out: 148mm x 332/482/632mm
- ◆ Option: Gasket & Brush





## ALUMINIUM DIE CAST SERIES



**Single Monitor**

Product Code  
• IS FX F



**Dual Monitor**

Product Code  
• IS FX 2 F



- ◆ Enhanced Ergonomics : Reduces risk of head , neck and eye strain
- ◆ Precision engineered to prevent cantilever effect
- ◆ Space Saving.
- ◆ Allows user to adjust the position of one or multiple screens with minimum effort and maximum precision
- ◆ Swivel , Tilt and 360° rotation allows you exceptional mobility
- ◆ Concealed cable management



**Dual Monitor Vertical  
(Short Link)**  
Product Code  
• IS FX 2 SL DV F



**Dual Arm with Freestanding Base**  
*Enquire for other Configurations*

Product Code  
• IS FX 2FS



**Partition Mount**  
Product Code  
• IS FX PM 02



**Dual Monitor  
(Vertical Mount)**  
Product Code  
• IS FX 2 DV F

### Partition Mount

- ◆ Height Adjustable
- ◆ Keeping monitor off the table will help to save table space. One can plan 6" shorter table , and save cost
- ◆ Increased viewing Comfort. Reduced Eye, Back and Neck Strain
- ◆ Portrait and landscape viewing option
- ◆ Compatible with all VESA Standard Monitors (75mm x 75mm and 100mm x 100mm)
- ◆ Suitable for fixing on Partition as well as on Wall
- ◆ Supports monitor upto 8 kgs





**Trio Monitor**

Product Code  
IS FX 3T F



**Quad Monitor**

Product Code  
IS FX 4 F



**Flexi Thin Client Holder**

Product Code  
• IS TCH FX



**Dual Monitor  
(Back to Back)**

Product Code  
• IS FX 2 BB F



**Single Monitor - Short Link**

Product Code  
• IS FX SL F

**Flange Mount**



**Clamp Mount**





**Dual Monitor**  
(Short Link)

Product Code  
• IS EV 2 SL F



**Single Monitor**

Product Code  
• IS EV F  
• IS EV C  
(With Clamp)



**Single Monitor** (Short Link)

Product Code  
• IS EV 1 SL F



**Double Monitor**

Product Code  
• IS EV 2 F

- ◆ **Adjust Monitor as per individual user comfort - Height, Distance & Angle**
- ◆ **Space Saving.** Since Footprint of stand is much less than footprint of monitor base, architects can shorten table depth by 6"
- ◆ Portrait and Landscape viewing options
- ◆ Compatible with all VESA Standard Monitors (75mm x 75mm and 100mm x 100mm)
- ◆ With Cable Management for neat wiring
- ◆ Each arm supports monitor upto 10 kgs



**Double Monitor (Vertical Mount)**

Product Code  
• IS EV 2 DV F



**Three Monitor (Horizontal)**

Product Code  
• IS EV 3 F (H)

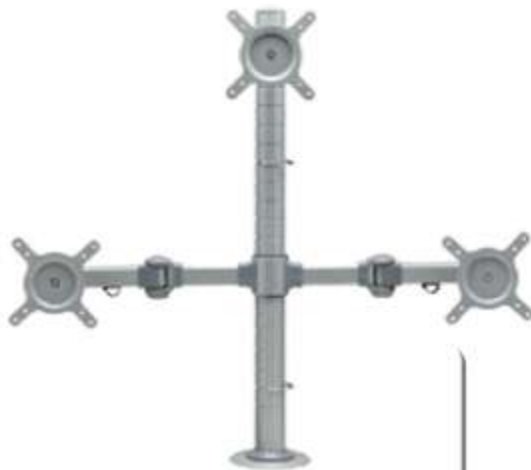

**Three Monitor (Triangular)**

Product Code  
• IS EV 3 F (T)

### Partition Mount (Single Link)



± 45° Tilt  
± 30° Swivel

Product Code  
• IS EV WM S

Colour: Metallic Silver Grey

### Partition Mount (Double Link)



± 45° Tilt  
± 60° Swivel

Product Code  
• IS EV WM D

Colour: Metallic Silver Grey

### PARTITION MOUNT

- ◆ Keeping monitor off the table will help to save space. One can plan 6" shorter table. Hence cost of table is reduced.
- ◆ Increased viewing Comfort. Reduces Eye, Back & Neck Strain
- ◆ Portrait & Landscape viewing option
- ◆ Compatible with all VESA Standard Monitors (75mm x 75mm and 100mm x 100mm)
- ◆ Suitable for fixing on Wall as well as on Partition
- ◆ Supports monitor upto 10 kgs

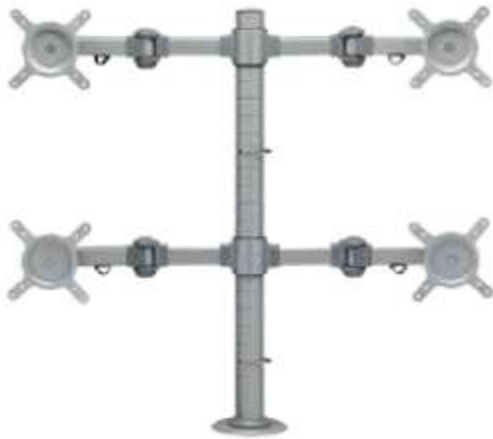

**Four Monitor**

Product Code  
**• IS EV 4 F**



**Flexi Thin Client Holder**

Product Code  
**• IS TCH EV**



**Four Arm with Freestanding Base**

*Enquire for other Configurations*

Product Code  
**• IS EV 4 FS**



## LAPTOP STAND



- ◆ Desk mounted Laptop Stand
- ◆ Robust Ergonomic Design
- ◆ For Laptops upto 15.6 inches
- ◆ Swivel and height adjustable
- ◆ Saves table space
- ◆ Option of Clamp mount or Flange mount
- ◆ Colour: Metallic Silver Grey

Product Code  
• IS EV LPTS F  
• IS EV LPTS C



5 Years Warranty T & C Apply

## MONITOR ARM WITH LAPTOP HOLDER



Product Code  
• IS EV MA LPT F  
• IS EV MA LPT C



Due to constant improvement, specifications are subject to change without notice



# TILT, SWIVEL, BEND OR PIVOT

- ◆ Rugged gas spring mechanism
- ◆ Extremely easy to adjust to desired position
- ◆ Quick release vesa mount
- ◆ Height and distance adjustable
- ◆ Size of monitor upto 32"
- ◆ Concealed cable management
- ◆ Both Clamp and Flange mounting solutions included



**EasyMove Single Arm**

Product Code  
• IS 360 EM 1



**EasyMove Dual Arm**

Product Code  
• IS 360 EM 2



# LARGEST RANGE OF TROUBLEFREE KEYBOARD DRAWERS

## KBD SOLUTIONS (PLASTIC)

### Keyboard Drawer (Denzo)



- ◆ **Large Pencil Compartment**
- ◆ Tray Size: 535mm (W) x 200mm (D)

#### Product Code

- IS KD Denzo (Basic)
- IS KD Denzo MT

(With Mouse Tray)

Colour : Black

### Keyboard Drawer (Denzo) with SoftPAD

- ◆ **With Cushioned SoftPAD**
- ◆ Tray Size: 535mm (W) x 200mm (D)

#### Product Code

- IS KD Denzo SP
- IS KD Denzo SP MT

(With Mouse Tray)

### Keyboard Drawer (Plastic) - KD 575



Colour : Black

- ◆ **Integral Pencil Holder**
- ◆ Tray Size: 575mm (W) x 300mm (D)

#### Product Code

- IS KD 575 P
- IS KD 575 P MT

(With Mouse Tray)

## KBD SOLUTIONS (METAL)

### Keyboard Drawer (Metal) 25"



Colour : Black

- ◆ **Accommodates Mouse alongside Keyboard**
- ◆ Tray Size: 645mm (W) x 225mm (D)

#### Product Code

- IS KD 645 M
- IS KD 645 M SP

(With SoftPAD)

### Keyboard Drawer (Metal) 19"



Colour : Black

- ◆ **With High Performance Imported Slides**
- ◆ Tray Size: 510mm (W) x 200mm (D)

#### Product Code

- IS KD 510 M
- IS KD 510 M MT

(With Mouse Tray)

### Keyboard Drawer (Metal) 19" with SoftPAD

- ◆ **With Cushioned SoftPAD**
- ◆ Tray Size : 510mm (W) x 200mm (D)

#### Product Code

- IS KD 510 M SP
- IS KD 510 M SP MT

(With Mouse Tray)

### Keyboard Drawer (Metal) 19" SST



Colour : Black

- ◆ **With High Performance Imported Slides**
- ◆ Tray Size : 510mm x 200mm (D)
- ◆ Economical

#### Product Code

- IS KD 510 M SST
- IS KD 510M MT SST

(With Mouse Tray)

**CPU Trolley**



Colour : Black

- ◆ With lockable castors for easy mobility
- ◆ Width Adjustable (150mm to 225mm)

Product Code  
• IS CPU TR

**CPU Trolley SST**



Colour : Black

- ◆ With lockable castors for easy mobility
- ◆ Width Adjustable
- ◆ Economical

Product Code  
• IS CPU SST

**CPU Trolley (Terra)**



Colour : Black

**CPU Terra**

- ◆ With lockable castors for easy mobility
- ◆ Width Adjustable (150mm to 225mm)
- ◆ Stylish
- ◆ Flat pack. Tool less assembly

Product Code  
• IS CPU Terra  
• IS CPU Terra SLM

Also available in **Slim Version**  
Width Adjustable (75 -150)

**CPU Holder (Side Mounting)**



Colour : Black

- ◆ Width Adjustable (150mm to 225mm)
- ◆ Sleek, elegant looks

Product Code  
• IS CPU HL SM

**CPU Holder (Fixed)**



Colour : Black

**CPU Holder**

- ◆ Width Adjustable (150mm to 225mm)
- ◆ Height Adjustable (300 mm to 475 mm)

Product Code  
• IS CPU HL  
• IS CPU HL SLM

Also available in **Slim Version**  
Width Adjustable (80-120)

**CPU Holder (Swivel & Pull Out)**



Colour : Black

- ◆ Swivel & pull out for easy access to the rear of the CPU
- ◆ 360° Swiveling
- ◆ Height Adjustable (300mm to 425mm)
- ◆ Width Adjustable (150mm to 225mm)

Product Code  
• IS CPU HL SW PL  
• IS CPU HL SW

Also available in **Swivel** only



## ErgoREST- Footrest

**GOOD POSTURE  
STARTS FROM YOUR FEET.**



Colour : Black

- ◆ Ergonomic Footrest
- ◆ Promotes Stress free posture
- ◆ Angle adjustable
- ◆ Slip resistant surface
- ◆ Reduces pressure on the back of the thigh
- ◆ Platform Size : 445mm (W) x 295mm (D)

Product Code  
• IS ER 445

## Stationery Organiser

Product Code  
• IS SO LK



Colour : Black

- ◆ Keeps your desk organised and stationery items handy
- ◆ Intelligent Design
- ◆ Sleek & Sturdy
- ◆ Made from High Impact Polystyrene  
Can be installed below Table Top and above Keyboard Drawer
- ◆ Size: 402 mm x 218 mm

**COMPLETE CONVENIENCE AT YOUR FINGERTIPS**

## EasyFit Metal Drawer

• EasyFit Drawer - Big



Product Code  
• IS ED 4130 F

Dimension:  
415mm (W) x 300mm (D) x 60mm (H)

• EasyFit Drawer - Small



**COST-EFFECTIVE ALTERNATIVE  
TO 3 DRAWER PEDESTAL**

Product Code  
• IS ED 3025 F

- ◆ Ready to install
- ◆ Slides and Mounting brackets included
- ◆ Can use wooden facia instead of metal facia

Dimension:  
215mm (W) x 320mm (D) x 60mm (H)

### Partition Holder

Product Code  
• IS PH 01

- ◆ For all types of screens (Glass, Acrylic, MDF etc)
- ◆ Width Adjustable
- ◆ Available in White and M.S.G



### Thin Client Holder

- ◆ Saves table space
- ◆ 360 degrees swiveling. Easy access to rear panel
- ◆ Height adjustable (30mm to 50mm)



Product Code  
• IS TCH 01

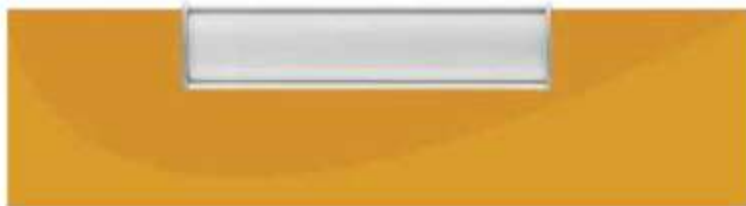

Product Code  
• IS NP 50210

### Name Plate

- ◆ Size : 210mm (L) x 50mm (H)
- ◆ Various mounting options available
  - Z type
  - U type
  - Plain
- ◆ Can also be customized

## Vertebrae



Spring Tube

Product Code  
• IS SGT 01

Colour: Ivory

- ◆ Vertical Cable Manager
- ◆ Material : Plastic
- ◆ Height : 740mm



Rectangular

Product Code  
• IS VBT R 740

Colour: Silver Grey & White



Oval

Product Code  
• IS VB 740

Colour: Silver Grey

## Vertebrae for Height Adjustable Table



- ◆ Vertical Cable Manager for Height Adjustable Tables
- ◆ Material Plastic

Rectangular

Product Code  
• IS VBT R 1200

Colour: Silver Grey & White

## LIST OF INSTALLATIONS

### BFSI

- Citi
- ICICI Bank
- HSBC
- HDFC Bank
- Morgan Stanley
- BNP Paribas
- Standard Chartered
- Axis Bank
- State Bank of India
- JPMC
- Nomura
- Birla Sunlife Insurance
- Kotak
- Motilal Oswal Securities
- HDFC Standard Life
- Bombay Stock Exchange
- Edelweiss
- IDFC
- SBI General Insurance
- Franklin Templeton

### CORPORATES

- Mercedes Benz
- Fedex
- Bajaj Auto
- Larsen & Turbo
- UPS
- Dupont
- Boeing
- Kia Motors
- Airbus
- Samsung
- NDTV
- HUL
- Asian Paints
- Suzlon
- Hyatt Regency
- Taj Group
- Cap Gemini
- Dassault

### TELECOM INDUSTRY

- Airtel
- Tata Telecom
- Reliance Telecom
- Ericsson
- Nokia

### IT/ITES

- IBM
- Dell
- HP
- Google
- Microsoft
- TCS
- Wipro
- Infosys
- Directi
- Genpact

### EDUCATIONAL INSTITUTES

- IIM
- IIT- MUMBAI
- D.Y.PATIL
- NID
- SVKM
- Ryan International School

**INNOFITT™**  
Intelligent Workplace Solutions

Mumbai | Pune | Bangalore | Delhi NCR

#### CORPORATE OFFICE & DISPLAY

No. 506 Ascot Centre, Sahar Airport Rd, Behind Hyatt Regency,  
Andheri East, Mumbai 400099.

Enquiry Hotline: 1800 103 3464 | Email: sales@innofitt.com

#### MANUFACTURING PLANT & DISPLAY CENTRE

Plot No. 114, Ramtekdi Industrial Estate,  
Near Emerson Power, Hadapsar,  
Pune - 411 013, India.